

**CITY OF HORICON
NOTICE OF COUNCIL MEETING
AUGUST 31, 2021 6:00 P.M.
CITY HALL, ACTIVITY ROOM, 404 E. LAKE STREET**

1. Call to Order.
2. Roll Call.
3. Pledge of Allegiance.
4. Act on Council Minutes of July 27, 2021.
5. Public Appearances.
6. Personnel & Finance Committee Report. (Frami)
7. Public Works & Development Committee Report. (Miller)
8. Public Safety Committee Report. (Marschke)
9. Park and Recreation Board Report. (Bandsma)
10. Plan Commission Report. (Maas)
11. Act on Acceptance of Kayaks, Equipment, and Storage from Friends of Horicon Marsh as the Kayak Project for Installation in Bowling Green Park. (Maas)
12. Act on Memorial Request for Kayak Project in Bowling Green Park. (Maas)
13. Act on Temporary Class "B" Retailer's License Application for Horicon Phoenix Program. (Marschke)
14. Act on Use of Kiwanis Park by Horicon Phoenix Program. (Bandsma)
15. Act on Request for Use of Amplified Music in Kiwanis Park by Horicon Phoenix Program. (Bandsma)
16. Act on Request for Use of River Bend Park by Horicon School District for Cross Country Meets. (Bandsma)
17. Act on 2021 Street Maintenance Projects. (Frami)
18. Act on Grit System Suction Piping Upgrade – to Include Funding. (Frami)
19. Act on Horicon Police Chief Hiring Process.

20. Operator Licenses (Marschke):
- a) One Year Ending June 30, 2022
None
 - b) Two Year Ending June 30, 2023
Susan D. Hady, JoAnne M. Link

21. Act on Financial Statement for July. (Frami)

22. Act on Bills for July 2021. \$2,315,242.05 (Frami)

23. Non-Action Discussion.























24. Adjourn.

Posted: 08/27/2021 9:30 a.m.

cc: Dodge County Pionier 08/27/2021
Daily Citizen
W.B.E.V. W.M.R.H. W.M.D.C.

City of Horicon

Legend

-  Parcel
-  Parent Labels
-  CSM Rebound
-  CSM Lot
-  Site and Grade Lot
-  Enumeration
-  ROW
-  Address Point
-  Address Label
-  Driveway
-  Building Footprint
-  City and Village (scale below 25K)
-  Township
-  Section
-  State Road
-  County Road
-  Federal Road
-  Interstate
-  Canal/Inlet
-  Lakes and Rivers
-  Horicon Marsh
-  Surrounding Counties



DISCLAIMER: This map is not guaranteed to be accurate, correct, current, or complete and conclusions drawn are the responsibility of the user.

Bowling Green Park Kayak Rack

10/23/17 2:23 AM	
------------------	---

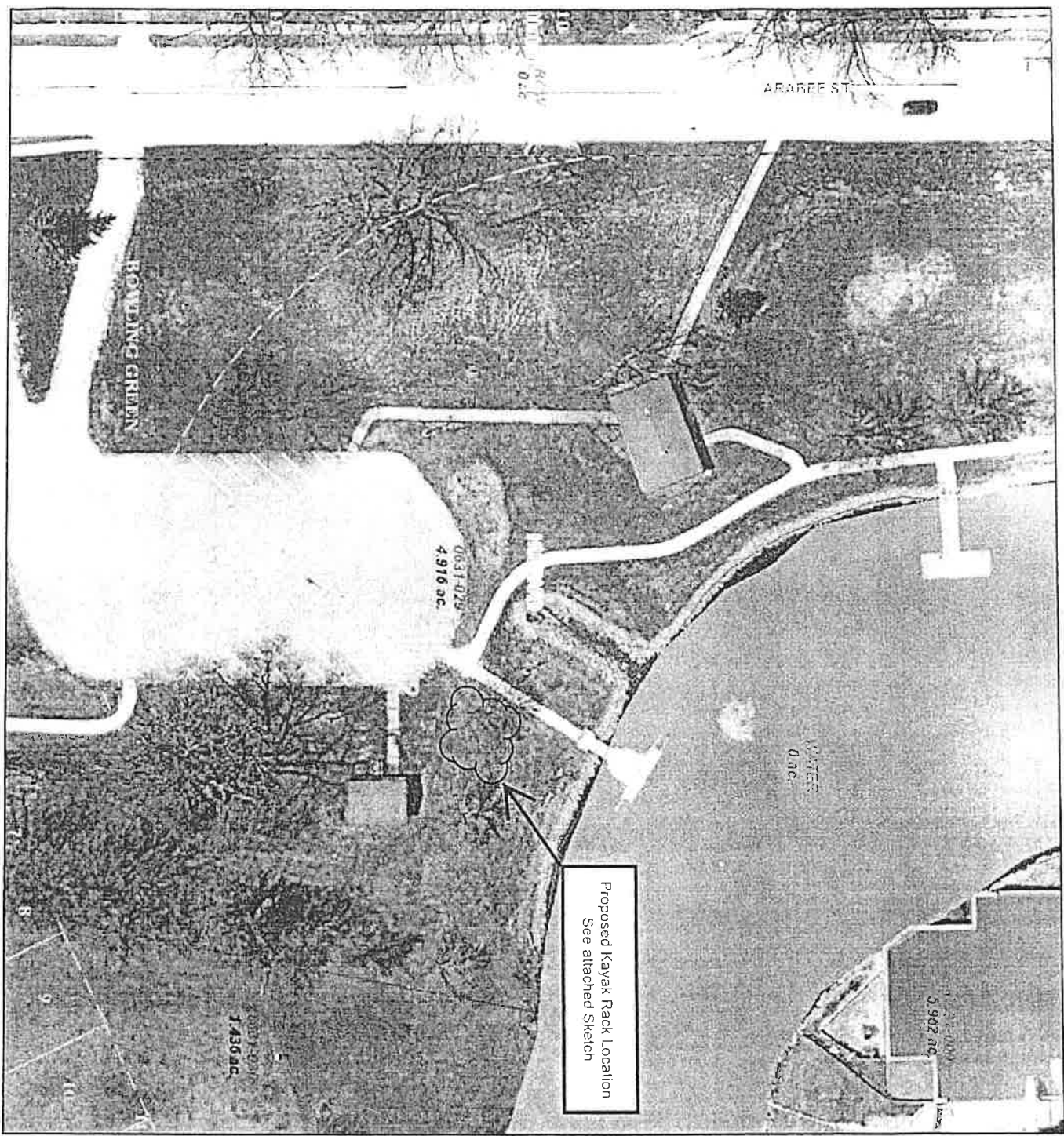

Proposed Kayak Rack Location
See attached Sketch

Kayak Rack Installation

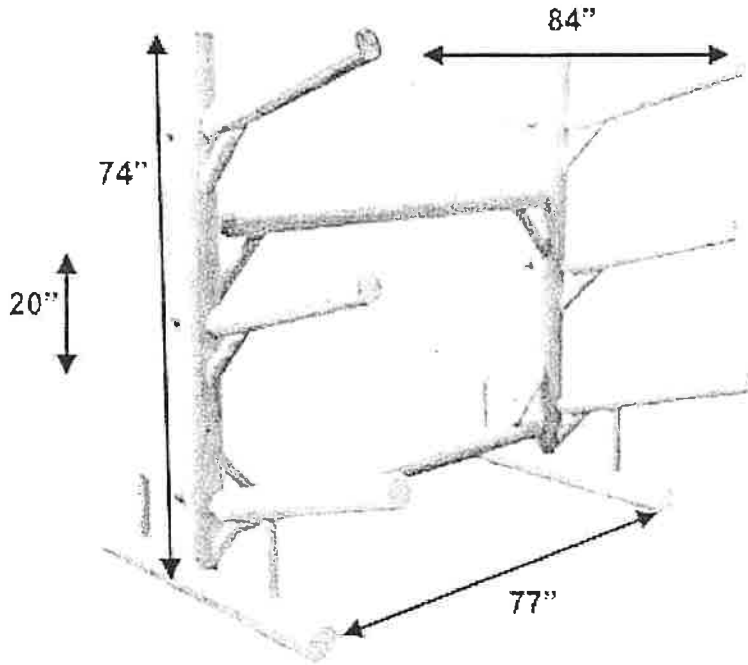

Explore Features | Need Help? | 1-866-333-3551

Close

180 Gal. Resin Storage Deck Box in Brown

by Cosco

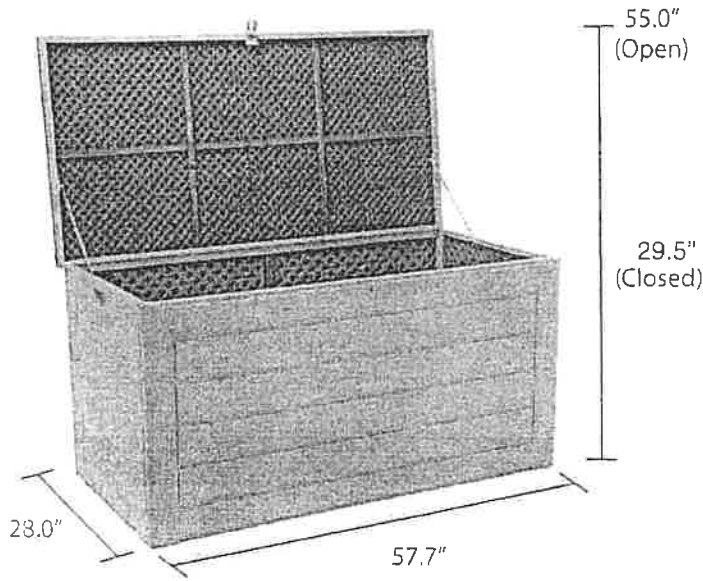

Hover Image to Zoom

Product Images

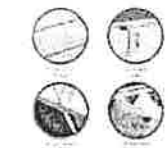

Save to List

Sign 1

For Your Safety

1. Follow All Applicable DNR and Local Instructions
2. Wear A Personal Floatation Device
3. Use the Buddy System
4. Follow the Rule of 120⁰ (Water temp. + Air temp. > 120⁰F)
5. Tell Someone Where You Are Going and When You Will Return
6. Do Not Use Facilities After Dark
7. When In Doubt, Don't
8. No Glass Bottles
9. Check the Weather
10. Return All Equipment As You Have Found It

IN CASE OF EMERGENCY CALL 911

The City of Horicon will not be held liable for any injury or violation incurred while using equipment from this facility.

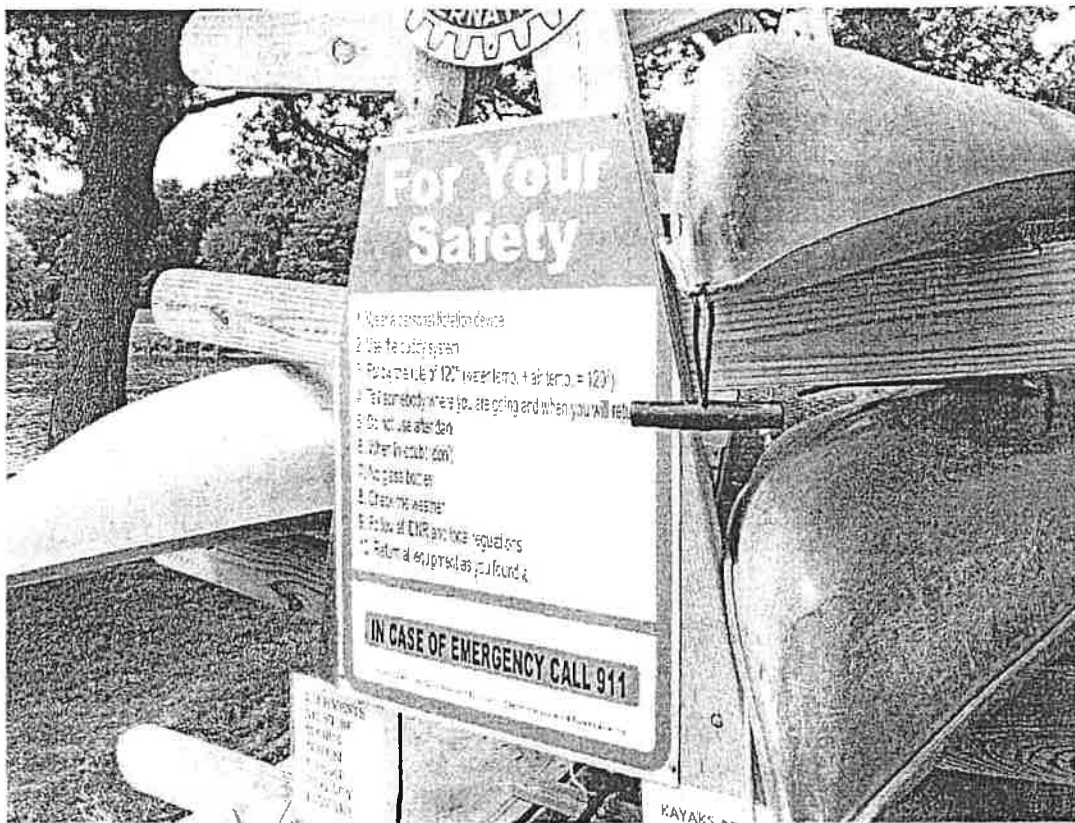

Sign 2

Kayak Instructions

1. Review Posted Safety Rules. Use of Kayak Is At Your Own RISK
2. Kayaks and Equipment Are Provided For User Enjoyment Without Charge. However, Users Will Be Responsible For Any Loss Or Damage During Use
3. Adult Supervision is Required for Anyone Under 18 years of age
4. Kayaks Are To Be Used along Rock River and Marsh Waterways Only. Removing Kayaks or Equipment From Site, Or Failure to Return Equipment, May Be Considered Theft
5. Abide by a Rule of 120. Do Not Kayak If Combined Temperature of Water and Air Does Not Exceed 120 °F
6. Return Kayak, Floatation Device, and Paddles by Sunset On Each Day of Use
7. Floatation Devices Must Be Worn by Each Person When Using Kayaks
8. Paddles. Select Two Halves of a Paddle That Are Marked With the Same Number. Paddles Available Can Be Used With All Kayak Models
9. Please Place Kayak, Paddles, and Floatation Device Back On Rack and In Storage Bin
10. If There Is A Problem With The Equipment or Facilities, Please Call Horicon DPW 920-485-3540

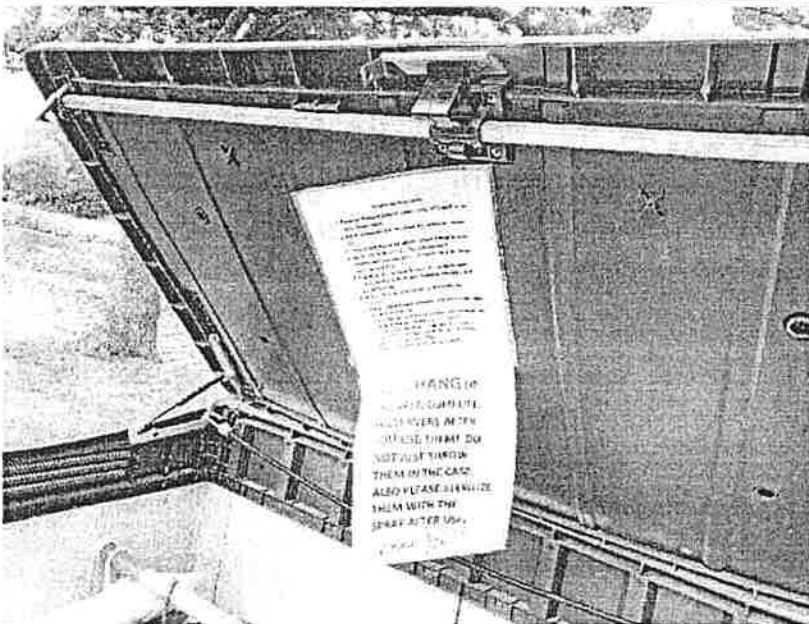

Sign 3

PLEASE STERILIZE AND
HANG UP WET LIFE
PRESERVERS AFTER
YOU USE THEM. DO
NOT JUST THROW
THEM IN THE BASE OF
STORAGE BIN.

THANK YOU

Sign 4

NOTICE

This area is under
24- Hour Video
Surveillance



FRIENDS OF
Horicon Marsh
EDUCATION &
VISITOR CENTER

Connecting People & Wildlife

August 9, 2021

Dear Mayor Grigg and City of Horicon Leaders:

On behalf of the Friends of Horicon Marsh Education and Visitor Center, we are excited to be working in joint efforts with the City of Horicon to bring a new kayak experience to Bowling Green Park. The original concept was sparked by conversations with our Friends Emeritus Director, Jerry Voy. Jerry has been instrumental bringing these ideas to light along with connecting our Friends organization and City of Horicon.

This project will provide a new kayak experience to Horicon and Horicon Marsh. Kayaks and equipment will be for public use at no cost to the user located at Bowling Green park near the current kayak launch. This project is an invaluable opportunity for our Friends organization and the City of Horicon to partner together. It's mutually beneficial for the city's recreation and tourism and to the Friends by promoting experiences at Horicon Marsh.

Friends of Horicon Marsh Education and Visitor Center will donate the funds necessary to bring this project to fruition; including but not limited to building materials and all kayak equipment (kayaks, paddles, and life preservers). We hope this donation along with our partnership with the City of Horicon be acknowledged with proper signage/plaque. Also on behalf of the Friends our Board of Directors, we would like to request an additional plaque or verbiage acknowledging the Voy family for their contributions to the Friends to help see this a reality.

We hope the City continue to share our enthusiasm for this project and possible future partnerships to enhance our City and Horicon Marsh experiences.

Thank you for your considerations.

Christine A. Oelke
Friends of Horicon Marsh, Board President

***Our Friends Mission:** Friends of the Horicon Marsh encourages and facilitates the connection between people and the Horicon Marsh. This is achieved through education and by fostering personal experiences in traditional outdoor activities within the marsh. Significant emphasis is placed on conserving and enhancing the marsh's natural resources. Mission objectives are achieved through collaboration, financial support and volunteer assistance to the Wisconsin Department of Natural Resources.*

CC: Tim Kingman



Making Horicon a better place to live



July 15, 2021

To: Horicon Parks Board
Cc: Mayor Grigg
Kristen Jacobson, City Clerk/Treasurer
Horicon City Council

Re: 2021 Horicon Phoenix Program Farmers Market, Summer Concert Series, and Community Garden

Dear Horicon Parks Board,

This letter is to request permission for the Horicon Phoenix Program to:

1. Host **summer concert series and farmers market rain date in Kiwanis Park on Wednesday, September 1, 2021**
2. Have **amplified music in Kiwanis Park** each Wednesday, September 1, 2021
3. Use the **Kiwanis Park building for food sales** on Wednesday, September 1, 2021
4. Have **beer sales in Kiwanis Park** on Wednesday, September 1, 2021

Let us know if you have any questions.

Sincerely,

Christine Schmitz, President
Liz Darner, Executive Director

Application for Temporary Class "B" / "Class B" Retailer's License

See Additional Information on reverse side. Contact the municipal clerk if you have questions.

FEE \$ 10/week

Application Date: _____

Town Village City of Horicon

County of Dodge

The named organization applies for: (check appropriate box(es).)

A Temporary Class "B" license to sell fermented malt beverages at picnics or similar gatherings under s. 125.26(6), Wis. Stats.

A Temporary "Class B" license to sell wine at picnics or similar gatherings under s. 125.51(10), Wis. Stats.

at the premises described below during a special event beginning 9-1-2021 and ending 9-1-2021 and agrees to comply with all laws, resolutions, ordinances and regulations (state, federal or local) affecting the sale of fermented malt beverages and/or wine if the license is granted.

Non-Profit Organization

1. Organization (check appropriate box) →
- Bona fide Club Church Lodge/Society
- Chamber of Commerce or similar Civic or Trade Organization
- Veteran's Organization Fair Association

(a) Name Horicon Phoenix Program

(b) Address 319 E Lake Street Horicon
(Street) Town Village City

(c) Date organized 2007

(d) If corporation, give date of incorporation _____

(e) If the named organization is not required to hold a Wisconsin seller's permit pursuant to s. 77.54 (7m), Wis. Stats., check this box:

(f) Names and addresses of all officers:

President Christine Schmitz

Vice President Kathryn Knop

Secretary Lahnie Neu

Treasurer Jennifer Rabehl

(g) Name and address of manager or person in charge of affair: Liz Darner

2. Location of Premises Where Beer and/or Wine Will Be Sold, Served, Consumed, or Stored, and Areas Where Alcohol Beverage Records Will Be Stored:

(a) Street number Kiwanis Park, 760 S Hubbard Street, Horicon

(b) Lot _____ Block _____

(c) Do premises occupy all or part of building? No

(d) If part of building, describe fully all premises covered under this application, which floor or floors, or room or rooms, license is to cover:

3. Name of Event

(a) List name of the event Horicon Phoenix Program Music at the Market

(b) Dates of event _____

DECLARATION

The Officer(s) of the organization, individually and together, declare under penalties of law that the information provided in this application is true and correct to the best of their knowledge and belief.

Officer Christine Schmitz 7/15/2021
(Signature/date)

Officer Kathryn A. Knop 7/15/2021
(Signature/date)

Horicon Phoenix Program
(Name of Organization)

Officer Jennifer Rabehl 7/15/2021
(Signature/date)

Officer Lahnie Neu 7/15/2021
(Signature/date)

Date Filed with Clerk _____

Date Reported to Council or Board _____

Date Granted by Council _____

License No. _____

SCHOOL DISTRICT OF HORICON

Home of the Marshmen

July 29, 2021

Requesting use of River Bend Park for Horicon High School Cross Country meets in 2021:

Horicon High School requests use of River Bend Park for the purpose of hosting Cross Country meets on the following dates:

Thursday, September 2, 2021

Thursday, September 23, 2021

Hours of use for each of those days:

Set-up of the course: Starting at 11:30am

Races: Starting at 4:00pm

Clean-up and departure by 7:30pm

Because runners will cross the roads inside the park, we plan to close down the park to auto traffic from 3:45pm to approximately 5:30pm.

Bus parking will be at the boat landing parking lot. Spectator parking will be at the ball field parking lots near the entrance to the park.

Thank you for your consideration.

Sincerely,



Mike LeBouton
Activities Director

Amy Rodriguez
Head XC Coach

VAN BRUNT ELEMENTARY SCHOOL
611 MILL STREET
HORICON, WI 53032
PH: (920) 485-4423
FAX: (920) 485-4318

DISTRICT OFFICE
611 MILL STREET
HORICON, WI 53032
PH: (920) 485-2898
FAX: (920) 485-3601

HORICON JUNIOR-SENIOR HIGH SCHOOL
841 GRAY STREET
HORICON, WI 53032
PH: (920) 485-4441
FAX: (920) 485-3244

Area Office
N5805 County Rd. M
Plymouth, WI 53073
Contracts.North@walbecgroup.com



Daniel H. Mueller
Direct: 920-926-7104
Cell: 920-579-1100
Fax: 920-921-7330
dmueller@neasphalt.com

QUOTATION

QUOTATION TO:

City of Horicon
404 E. Lake St.
Horicon, WI 53032

Date: July 7, 2021

Plan Date:

Project Name: C/O Horicon Overlay

Project Location:

W. Walnut

- 2" Profile Mill and asphalt surface course.

UNIT PRICE: \$105.70 / TN
ESTIMATED TOTAL: 210 TN X \$105.70 = \$22,197.00

Cemetery Rd.

- 2" Profile Mill and asphalt surface course.

UNIT PRICE: \$105.70 / TN
ESTIMATED TOTAL: 140 TN X \$105.70 = \$14,798.00

DPW

- Install a 3" average depth asphalt pavement on approximately 815 sy.

UNIT PRICE: \$76.10 / TN
ESTIMATED TOTAL: 175 TN X \$76.10 = \$13,317.50

INCREASE TO 2006 SY
ESTIMATED 430.7 TON
430.7 TON @ \$76.10 → \$32,776

Notes:

1. Due to the volatility of the petroleum markets, please be aware of the time and date requirements as set forth below for the acceptance of this proposal.
2. Landscape restoration to be completed by others.
3. Price does not include any undercutting of unsuitable soils.
4. Price includes one (1) mobilization.
5. The above price is based upon the site allowing for a minimum of 1% drainage. If 1% drainage is not obtainable water ponding may occur.

*If you have any questions on this Quotation, please call me at the contact information listed above.
Thank you!*

IF THIS QUOTATION IS NOT ACCEPTED AND RETURNED WITHIN 30 DAYS FROM THE DATE OF THIS QUOTATION OR IF THE WORK IS NOT COMPLETED BY November 15, 2021, NORTHEAST ASPHALT, INC. RESERVES THE RIGHT TO WITHDRAW THE QUOTATION OR MODIFY THE TERMS OF THE QUOTATION/CONTRACT.

QUOTE



W3150 County Road H, Fond du Lac, WI 54937
920-579-2731

bparkhurst@sabelmechanical.com

QUOTE #: 7368

SEND TO Tim Kingman Horicon WWTP

Date	Job	Payment Term	QUOTE EXPIRES
7/27/21	Grit Suction Piping Rehab	30 DAYS	Today

QTY	DESCRIPTION	UNIT PRICE	LINE TOTAL
1 LS	<p>Installation of new 4" grit suction piping to include the following:</p> <p>(1) 4" DI Tee (1) 4" x 4' DI riser pipe (1) 4" DI blind flange</p> <p>Includes removal of 4" 90 degree elbow inside grit tank on the grit pump suction line and replace it with a 4" Tee and 4' riser pipe to have better access to clean the suction line.</p> <p>Excludes draining and cleaning of the grit tank.</p> <p>Inspect/troubleshoot grit pump and replace packing.</p> <p>Due to the fluctuating material pricing and availability, quote is valid thru end of today's business day, Pricing may have to be adjusted at time of purchase and will be reflected when project is invoiced</p> <p>Accepted _____ Date _____</p>		\$4,215.00

PAST DUE AMOUNTS ARE SUBJECT TO A FINANCE CHARGE AT THE MAXIMUM RATE ALLOWED BY STATE. REASONABLE COLLECTION FEES AND ATTORNEY FEES WILL BE ASSESSED TO ALL ACCOUNTS PLACED FOR COLLECTION

SUBTOTAL	\$
SALES TAX	\$ NIC
TOTAL	\$

Horicon Police Chief Hiring Process

08/03/2021

1. INTERNAL CANDIDATES

- a. Pursuant to the City of Horicon Personnel Policy Manual, the City will post the Police Chief position for a period of five (5) workdays.
- b. Employees wishing to “bid” for the vacancy must submit an letter of interest, resume, and application of employment to the City Clerk at City Hall.
- c. Applicants will be reviewed by the Selection Panel, as defined below, to determine the qualifications of the internal applicants.

2. EXTERNAL SEARCH

- a. In the event that the Selection Panel determines that none of the employees who post or bid for the vacancy and/or promotion are qualified for the position, the City will seek qualified employees from outside City employment.
- b. Advertisement for the position will go public upon the determination that no internal candidate is qualified.
 - i. Advertisements will be placed on the following websites:
 1. WI League of Municipalities
 2. Wilenet
 3. WI Chiefs of Police website
- c. Applications from external candidates will be accepted by the City Clerk at City Hall for a period of [INSERT TIMEFRAME IN WEEKS] from the date the advertisements are posted.
- d. Applications will be reviewed by the Selection Panel to determine the qualifications of the external applicants.

3. SELECTION PANEL

- a. The Selection Panel will consist of 3 current WI Police Chiefs.
 - i. A list of not less than twelve (12) names for the City Clerk and Mayor to consider for the panel will be provided by the Wisconsin Chiefs of Police Association.
- b. The Selection Panel will interview internal candidates and external candidates, if necessary, whose applications were received by the City Clerk to determine the qualifications of the applicants.
- c. The Selection Panel will forward its recommendation(s) to the Common Council.

4. COMMON COUNCIL INTERVIEW

- a. Final interviews will be conducted by the Common Council in Closed Session.
- b. The Common Council will determine the most qualified candidate for the position and recommend that candidate for the open position.
- c. The Mayor will have final authority to offer employment to the candidate recommended by the Common Council.

CITY OF HORICON
STATEMENT OF REVENUES AND EXPENSES
FOR MONTH ENDED JULY 31, 2021

	GENERAL FUND	WATER UTILITY	W. WATER UTILITY
CASH BALANCE, JULY 1, 2021	\$ 31,634.66	\$ 33,726.88	\$ 6,543.03
RECEIPTS	\$ 4,014,001.01	\$ 488,109.31	\$ 826,896.08
SUBTOTAL	\$ 4,045,635.67	\$ 521,836.19	\$ 833,439.11
EXPENDITURES	\$ 1,727,771.51	\$ 234.38	\$ 222.39
SUBTOTAL	\$ 2,317,864.16	\$ 521,601.81	\$ 833,216.72
PAYROLL	\$ 93,241.23	N/A	N/A
CASH BALANCE, JULY 31, 2021	\$ 2,224,622.93	\$ 521,601.81	\$ 833,216.72
BANK BALANCE, JULY 31, 2021	\$ 2,207,609.73	\$ 469,419.21	\$ 833,216.72
DEPOSITS IN TRANSIT	\$ 34,469.59	\$ 52,182.60	
SUBTOTAL	\$ 2,242,079.32	\$ 521,601.81	\$ 833,216.72
OUTSTANDING CHECKS	\$ 17,456.39		\$ -
BOOK BALANCE, JULY 31, 2021	\$ 2,224,622.93	\$ 521,601.81	\$ 833,216.72
FUNDS INVESTED:			
UNDESIGNATED:			
SAVINGS ACCOUNT			
L.G.I.P.	\$ 2,443,090.51		\$ 255,787.00
CD's	\$ 200,000.00		\$ 200,000.00
	\$ 2,643,090.51	\$ -	\$ 455,787.00
DESIGNATED:			
DEBT SERVICE		\$ 134,718.53	
DEBT RESERVE		\$ 116,317.20	
ARPA FUNDS	\$ 190,758.44	\$ -	
MUNICIPAL COURT SUSPENSE	\$ 1,116.07		
CABLE FRANCHISE FEES	\$ 87,544.50		
CAPITAL EQUIPMENT FUND	\$ 363,971.36		
CAPITAL PROJECT FUND	\$ 261,257.05		
COMMUNITY DEVELOP. AUTHORITY	\$ 6,208.22		
E.M.S. GRANT 102	\$ 7,371.84		
E.M.S. LONGEVITY	\$ 7,150.08		
FIREMEN'S PENSION FUND	\$ 10,551.96		
LIBRARY FUND	\$ 237,095.00		
REVOLVING LOAN FUND	\$ 12.72		
VEHICLE REGISTRATION	\$ 5,233.31		
TOWER LEASE DEPOSIT		\$ 13,014.28	
UTILITY DEPRECIATION		\$ 573,300.96	\$ 248,572.15
DNR REPLACEMENT FUND			\$ 386,607.96
SEWER REPLACEMENT FUND			\$ 156,435.68
LIFT REPLACEMENT FUND			\$ 15,049.40
TOTAL DESIGNATED	\$ 1,178,270.55	\$ 837,350.97	\$ 806,665.19
TOTAL INVESTMENTS	\$ 3,821,361.06	\$ 837,350.97	\$ 1,262,452.19

APPROVED BY CITY COUNCIL

31-Aug-21

 JAMES R. GRIGG, MAYOR

 FORREST A. FRAMI, CHAIRPERSON PERSONNEL & FINANCE